

"EASY STREET" PRINTABLE TEMPLATE

HO MODE - LEFT HAND 8" and 10" RADIUS TURNOUTS AND FULL 8"/10" CURVED DOUBLE JUNCTION

OPTIMIZED FOR NMRA HO RP25 WHEELSETS, RUNNING ON THEIR FLANGE TIPS,
AT REALISTIC SPEEDS.

DIAGRAMS BASED ON TYPICAL US PROTOTYPICAL AAR DRAWINGS

USE THE 6" THICK BLACK REFERENCE BAR ABOVE
TO VERIFY THE DIAGRAM IS PRINTED TO SCALE.

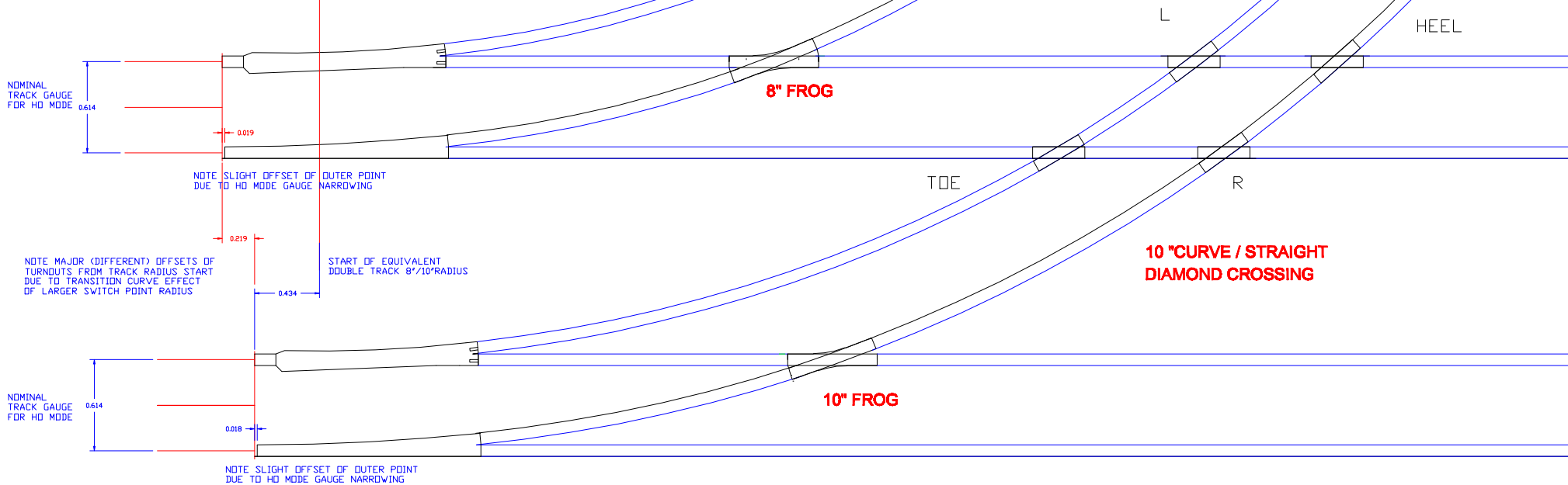

www.proto87.com

Copyright Andrew Reichert 1983, 2004, 2008

Provided solely for customer assistance. See associated help sheets for additional instructions

All rights reserved. No whole, part, or derivative reproduction for commercial use, without express written permission.